

# Standard Pump

## Industrial Pump Models: SP-700SR & SP-700DD

### Description

Standard's Drum Pumps are designed to transfer a variety of materials from 55 gallon drums and tanks. Standard Pump offers several different pumps, each designed for specific applications. Before operating, please confirm that the pump's materials of construction are suitable for the application.

### Unpacking

Cartons should be handled with care to avoid damage from dropping, etc. After unpacking, inspect carefully for any damage that may have occurred during transit. Check for loose, damaged or missing parts.

### General Safety Information

The responsibility for safe assembly, installation, and operation ultimately rests with the operator. Read and understand ALL safety precautions and operating instructions before operation. Careless pump operation can result in serious injury.

- Before operating the pump, read and understand these operating instructions.
- The operator should wear suitable protective clothing including the following: face mask, safety shield or goggles, gloves, apron, and safety shoes.
- Before operating, verify the materials being pumped are compatible with the pump's "wetted components."
- All Federal, State, and local safety codes should be followed.
- Verify that the motor voltage corresponds to proper electrical supply.
- Before plugging motor into power supply, make sure the motor switch is in the OFF position. For Air Motors ensure inlet valve is closed before attaching air line.
- Before operation, confirm all pump connections are properly tightened.
- First pump clean water in order to familiarize yourself with the pump's operation, flow rate, discharge pressure and motor speed.
- Before starting the pump, confirm the discharge hose is securely fastened to the receiving vessel in order to prevent splashing.
- Never leave pump unattended during operation.
- Do not submerge the motor in any liquid.
- When finished using the pump, flush the pump by pumping water or an appropriate cleaning solution. Do not use flammable or combustible cleaning solutions.
- Never carry the motor by the power cord.
- Never store pump in container. Always rinse pump thoroughly and hang on wall bracket or ensure pump tube is stored in an upright and vertical position.

### SP-700SR Specifications

Model	Immersion Length	Wetted Components			Motors Drives	Discharge Size	Max Viscosity cps (mPAS)*	Max Discharge Pressure	Max Flow Rate	Max Temp	Inlet Size	Max Solid Size	Duty Cycle
		Tube & Rotor	Stator	Mechanical Seal									
SP-700SR-751B	27" (700 mm)	SS316L	BUNA	SiC/Viton®/SiC	SP-ENC  SP-420EX	1.5" (38 mm) Hose Barb Optional 1.25 (32mm) Hose Barb Exposed Threads G 1.50"	25,000	87 psi (6 bar)	7 GPM(26 LPM)	185° F (85° C)	2" (51 mm)	.25" (6 mm)	Intermittent
SP-700SR-751P		SS316L	PTFE	SiC/Viton®/SiC			25,000	87 psi (6 bar)	7 GPM(26 LPM)	300° F (148° C)			Intermittent
SP-700SR-752B	39" (1000 mm)	SS316L	BUNA	SiC/Viton®/SiC			25,000	174 psi (12 bar)	7 GPM(26 LPM)	185° F (85° C)			Intermittent
SP-700SR-752P		SS316L	PTFE	SiC/Viton®/SiC			25,000	174 psi (12 bar)	7 GPM (26 LPM)	300° F (148° C)			Intermittent
SP-700SR-1851B	47" (1200 mm)	SS316L	BUNA	SiC/Viton®/SiC			10,000	87 psi (6 bar)	12 GPM (45 LPM)	185° F (85° C)			Intermittent
SP-700SR-1851P		SS316L	PTFE	SiC/Viton®/SiC			10,000	87 psi (6 bar)	12 GPM (45 LPM)	300° F (148° C)			Intermittent

\*Pump is intended for intermittent use when operating at maximum viscosity.

#### Notes

- Pump stator elastomer (PTFE & Buna) may vary performance.
- Performance is based on using a 900 RPM motor. Reducing motor speed will decrease pump performance.
- The SP-700SR Series pump is equipped with a gear reduction unit which reduces the speed of the pump to between 750 and 900 RPM. Therefore, the motor speed must not exceed 16,000 RPM's in order to achieve the proper operating RPM's of the pump.
- Performance will vary depending on whether the product being pumped is newtonian (viscosity remains constant regardless of shear) or non-newtonian (viscosity does not remain constant with shearing).
- Flow rates based on water. As viscosity increases, the flow rate will decrease.

**Industrial Pump Models: SP-700SR & SP-700DD**

**SP-700SR Motor Specifications**

Model	Voltage	Amps	Watts	HP	Phase	Hz	Enclosure	Variable Speed	Hazardous Duty	Shipping Weight
SP-420EX	230V	2.6	600	0.80	1	50-60	EXP (IP54)	N	AtEx	17 (7,7)
SP-ENG	110V	8.5	825	1	1	50-60	TEFC (IP54)	N	N	12.7 (5,7)
SP-ENG-V	110V	8.5	825	1	1	50-60	TEFC (IP54)	Y	N	12.7 (5,7)
SP-ENG-2	220V	5	825	1	1	50-60	TEFC (IP54)	N	N	12.7 (5,7)
SP-ENG-2-V	220V	5	825	1	1	50-60	TEFC (IP54)	Y	N	12.7 (5,7)

**SP-700SR**

**⚠ WARNING** *The SP-700SR Series Pump is recommended for intermittent duty use only. (ie., 30 minute intervals with a 10 minute cooling off period). For continuous duty applications, Standard Pump recommends using the SP-700DD Series Pump.*

**⚠ WARNING** *The SP-700SR Series Pump is positive displacement pumps and should never be operated against shut-off elements such as nozzles, valves, etc. Failure to comply may result in excessive pressure build resulting in serious injury and pump damage.*

**⚠ WARNING** *The SP-700SR Series Pump should not be run dry. Running the pump dry will result in serious damage to the mechanical seal and stator of the pump*

**Assembly (SP-700SR)**

1. Remove the pump and motor from packaging.
2. Inspect all contents for damages.
3. Couple the electric motor to the pump using the hex nut (see Figure 1).

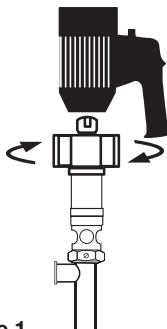

Figure 1

4. First pump clean water in order to familiarize yourself with the pump's operation, flow rate, discharge pressure and motor speed.

5. It is recommended to thoroughly clean and sanitize SP-700SR series pumps before operation (see page 4).
6. Use closed top drum or cover to prevent possible contamination.

**Operation (SP-700SR)**

1. Once the pump is fully assembled and all connections are fastened, insert the pump into the drum or tank (see Figure 2).

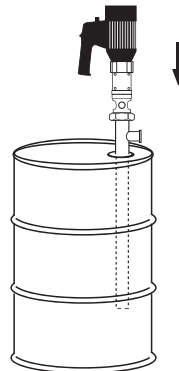

Figure 2

2. It is recommended to attach a suitable hose or pipe to the pump discharge.

**⚠ WARNING** *Make sure the hose meets the pump discharge pressure requirements (SP-700SR-751 or SP-700SR-1851= 87 psi (6 bar)) / (SP-700SR-752= 174 psi (12,1 bar)). It is recommended to use a hose that is rated 4 x the pump discharge pressure. Ex: 87 x 4= 348 psi (24,3 bar).*

3. If you opt to use a hose, fasten the hose to the hose barb with a suitable hose clamp that exceeds the pump discharge pressure.
4. Make sure the speed control knob on the motor is turned to the MIN position (completely counterclockwise).
5. Turn the motor switch to the ON position.
6. Slowly throttle the motor up by turning the speed control knob clockwise.

**⚠ WARNING** **⚠** *Do not use these pumps for the transfer of flammable or combustible products or in an environment where flammable or combustible fumes are present unless used in conjunction with Explosion Proof or Air motor as well as proper grounding and bonding wires. Please consult the factory or authorized distributor with any questions regarding installation (see page 7).*

**Maintenance & Disassembly (See page 4)**

## Industrial Pump Models: SP-700SR & SP-700DD

### SP-700DD Specifications

Model	Immersion Length	Wetted Components			Motors Drives	Discharge Size	Max Viscosity cps (mPAS)*	Max Discharge Pressure	Max Flow Rate	Max Temp	Inlet Size	Max Solid Size	Duty Cycle
		Tube & Rotor	Stator	Mechanical Seal									
SP-700DD-751B	27" (700 mm)	SS316L	BUNA	SiC/Viton®/SiC	TEFC, & Air	1.5" (38 mm) Hose Barb Optional 1.25 (32mm) Hose Barb Exposed Threads G 1.50"	100,000	87 psi (6 bar)	7 GPM(26 LPM)	185° F (85° C)	2" (51 mm)	.25" (6 mm)	Continuous
SP-700DD-751P		SS316L	PTFE	SiC/Viton®/SiC			100,000	87 psi (6 bar)	7 GPM(26 LPM)	300° F (148° C)			Continuous
SP-700DD-752B	39" (1000 mm)	SS316L	BUNA	SiC/Viton®/SiC			100,000	174 psi (12 bar)	7 GPM(26 LPM)	185° F (85° C)			Continuous
SP-700DD-752P		SS316L	PTFE	SiC/Viton®/SiC			100,000	174 psi (12 bar)	7 GPM (26 LPM)	300° F (148° C)			Continuous
SP-700DD-1851B	47" (1200 mm)	SS316L	BUNA	SiC/Viton®/SiC			10,000	87 psi (6 bar)	12 GPM (45 LPM)	185° F (85° C)			Continuous
SP-700DD-1851P		SS316L	PTFE	SiC/Viton®/SiC			10,000	87 p si (6 bar)	12 GPM (45 LPM)	300° F (148° C)			Continuous

\*Pump is intended for intermittent use when operating at maximum viscosity.

- Notes**
1. Pump stator elastomer (PTFE & Buna) may vary performance.
  2. Performance is based on using a 900 RPM motor. Reducing motor speed will decrease pump performance.
  3. Performance will vary depending on whether the product being pumped is newtonian (viscosity remains constant regardless of shear) or non-newtonian (viscosity does not remain constant with shearing).
  4. Flow rates based on water. As viscosity increases, the flow rate will decrease.

### SP-700DD Motor Specifications

Model	HP	KW	RPM	Enclosure	Frame	Flange	Air Consumption	Airline Size Inches	Shipping Weight
SP-502	0.75	.55	750-900	TEFC (IP55)	90LC	B14/C140	N/A	N/A	56 (25,5)
SP-512	1	.75	750-900	TEFC (IP55)	100LC	B14/C140	N/A	N/A	56 (25,5)
SP-522	1.5	1,1	750-900	TEFC (IP55)	100LC	B14/C140	N/A	N/A	78 (35,5)
SP-A4	2	1,5	300-900	N/A	IEC#72/D71	B14/C140	80 CFM @ 100 psi 37 L/Sec @ 7 Bar	3/8"	12.0 (5,0)
SP-A6	4	3,0	300-900	N/A	IEC#72/D71	B14/C140	130 CFM @ 100 psi 65 L/Sec @ 7 Bar	1/2"	24.0 (11,0)
SP-A8	5	3,7	300-900	N/A	IEC#72/D71	B14/C140	170 CFM @ 100 psi 80 L/Sec @ 7 Bar	1/2"	26.0 (12,0)
0017	Motor wiring for 230V/3/50-60 Hz. Includes parts 570, 571, 572, 8708.								

**Note:** For optimum performance when using an air motor make sure proper size air lines are installed.

### SP-700DD

**⚠ WARNING** *The SP-700DD Series Pump is positive displacement pumps and should never be operated against shut-off elements such as nozzles, valves, etc. Failure to comply may result in excessive pressure build resulting in serious injury and pump damage.*

**⚠ WARNING** *The SP-700DD Series Pump should not be run dry. Running the pump dry will result in serious damage to the mechanical seal and stator of the pump.*

#### Assembly (SP-700DD)

1. Remove the pump and motor from packaging.

2. Inspect all contents for damages.
3. Couple the motor to the pump. Bolt electric or pneumatic motor to the pump using the hardware provided by the manufacturer (see figure 3).
4. It is recommended to thoroughly clean and sanitize SP-700DD series pumps before operation.
5. Closed top drum or cover is recommended to prevent possible contamination.

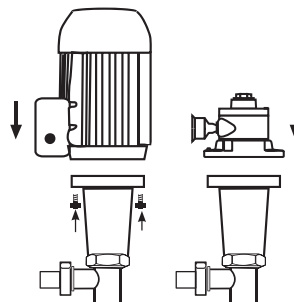
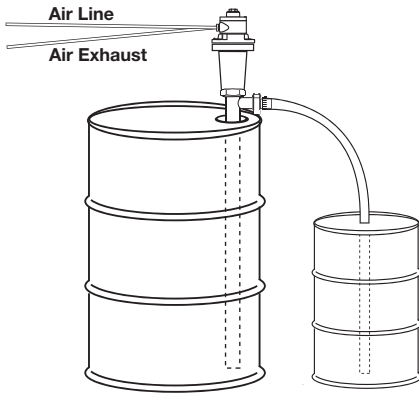

Figure 3

6. Motor
  - a) Electric – make sure motor and plug are wired to proper voltage and direction. Use wiring diagram on nameplate.
  - b) Air – for optimum performance make sure proper size air line & connection.

**Industrial Pump Models: SP-700SR & SP-700DD**

**Assembly (SP-700DD)  
(continued)**



**Note:** Recommend plumbing discharge air away from drum or tank to prevent possible contamination.

**⚠ WARNING** When using an SP-A4, SP-A6 or SP-A8 motor, Standard Pump recommends the use of a Fliter Lubricator Regulator (FLR) in order to ensure a moisture free supply of air to the motor.

**⚠ WARNING** Do not operate the SP-700DD-1851 series pump on viscosities greater than 10,000 cps (mPAS). Do not operate the SP-700DD-751 or SP-700DD-752 series pumps on viscosities greater than 100,000 cps (mPAS). Failure to comply will result in premature pump failure.

**⚠ WARNING** When using an SP-700DD pump in conjunction with an air motor (SP-A4, SP-A6 or SP-A8), make sure the air line is connected to the air inlet hole on the left side of the motor as you face the motor. This will insure that the motor turns in a clockwise direction. Use the pump arrow to verify proper direction. If the pump rotates counterclockwise, the internal components will disassemble.

**⚠ WARNING**  Do not use these pumps for the transfer of flammable or combustible products or in an environment where flammable or combustible fumes are present unless used in conjunction with Explosion Proof or Air motor as well as proper grounding and bonding wires. Please consult the factory or authorized distributor with any questions regarding installation (see page 7).

**Operation (SP-700DD)**

1. Once the pump is fully assembled and all connections are fastened, insert the pump into the drum or tank. Pump can be suspended from hoisting system using an optional pump hanger (P/N: 743).

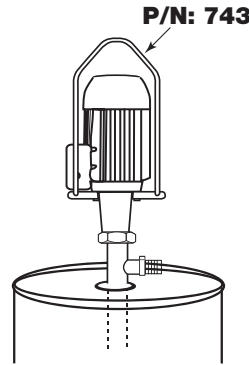

2. It is recommended to attach a suitable hose or pipe to the pump discharge.
3. If you opt to use a hose, fasten the hose to the hose barb with a suitable hose clamp that exceeds the pump discharge pressure.

**⚠ WARNING** Make sure the hose meets the pump discharge pressure requirements (SP-700DD-751 or SP-700DD-1851=87 psi (6 bar)) / (SP-700DD-752=174 psi (12,1 bar)). It is recommended to use a hose that is rated 4 x the pump discharge pressure. Ex: 87 x 4= 348 psi (24,3 bar).

**Maintenance**

**Disassembly / Cleaning Procedures (SP-700SR & SP-700DD)**

4. Remove motor from pump tube. For models SP-700SR: loosen Hex Nut in clockwise rotation (see Figure 3). For models SP-700DD: loosen (4) bolts that attach the pump to the motor (see Figure 4).

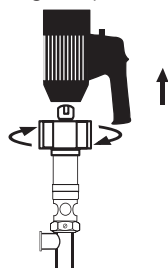

Figure 3

**NOTE:** Remove motor by turning hex nut clockwise

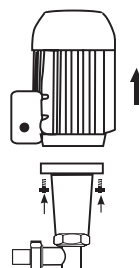

Figure 4

**NOTE:** Remove 4 bolts from motor flange.

5. Loosen set screw on side of Hex Nut (see Figure 5).
6. Place a screwdriver (or similarly shaped object) in the mechanical seal inspection port (see Figure 5).
7. Use a large wrench to loosen the Hex Nut while simultaneously holding the screwdriver in the seal inspection port (see Figure 5).

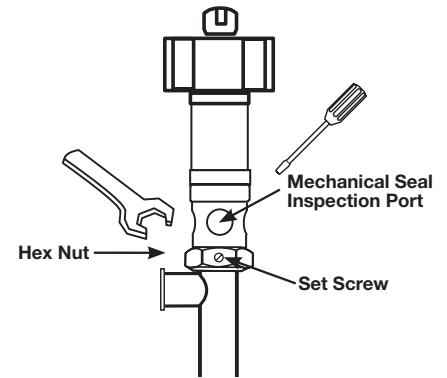

Figure 5

8. Once the Hex Nut is loosened, remove the outer tube from the drive shaft assembly (see Figure 6).

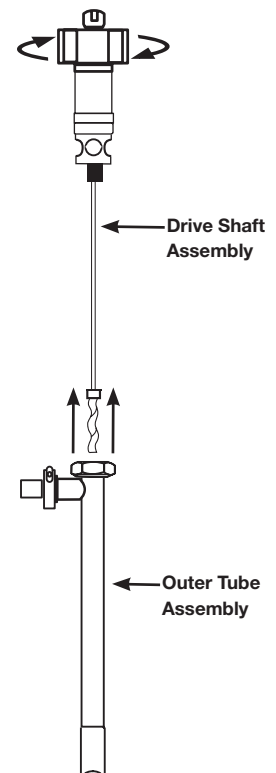

Figure 6

**Industrial Pump Models: SP-700SR & SP-700DD**

**Disassembly / Cleaning Procedures (continued)**

- Remove the stator from the pump tube body by turning clockwise (see Figure 7).

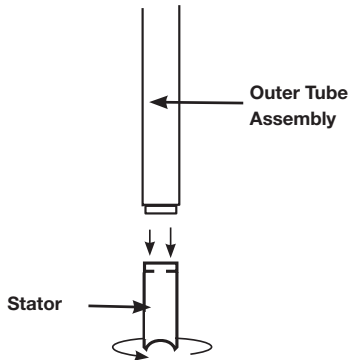

Figure 7

- Hold the drive shaft in a fixed position and loosen the rotor (counterclockwise) located at the bottom of the drive shaft (see Figure 8).

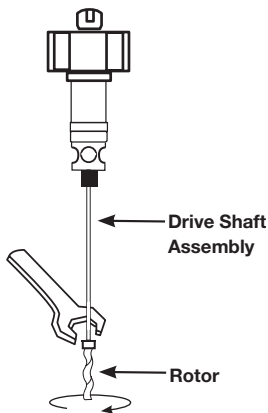

Figure 8

- Insert a small screwdriver (or similar object) through the small hole on the shaft located inside the mechanical seal inspection port (see Figure 9).
- While holding the small shaft still, loosen (counterclockwise) the pump drive shaft with large wrench. (see Figure 9).

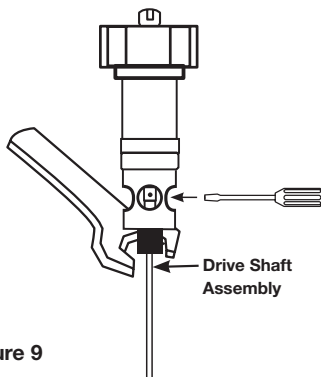

Figure 9

**Mechanical Seal Replacement / Pump Assembly (SP-700SR & SP-700DD)**

- Follow steps 1-9 under the Disassembly / Cleaning Procedures from above.
- The mechanical seal will be exposed in the lower portion of the mechanical seal bushing (see Figure 10).

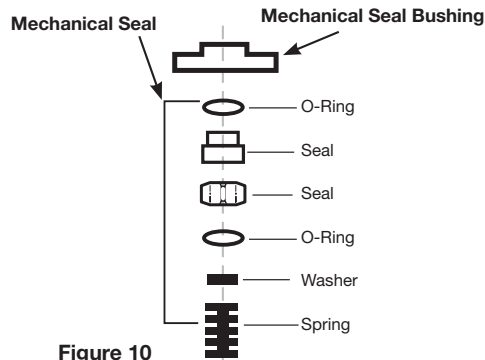

Figure 10

- Remove damaged seal and replace with a new mechanical seal. Use a suitable lubricant on the seals O-rings.

**⚠ WARNING** *Wear gloves when performing seal maintenance. Touching the seal face could cause premature failure.*

- Reinstall mechanical seal bushing into bearing housing.
- Thread drive shaft onto bearing housing shaft (see Figure 9).
- Thread rotor onto drive shaft (see Figure 8).
- Thread stator can onto pump body (see Figure 7).
- Apply a suitable lubricant on rotor.
- Once Bearing Housing, drive shaft, and rotor are securely threaded together, insert this assembly into the pump body (see Figure 6, page 4).
- Tighten the Hex Nut on the pump body to the Bearing housing. Use screwdriver (or similarly shaped object) in the mechanical seal inspection port (see Figure 5, page 4).
- Use a large wrench to tighten the Hex Nut while simultaneously holding the screwdriver in the seal inspection port (see Figure 5, page 4).
- Replace set screw into hex nut.
- Reattach motor and resume operation. (SP-700SR: see Figure 3, page 4); (SP-700DD: see Figure 4, page 4).

**TFE Series Only**

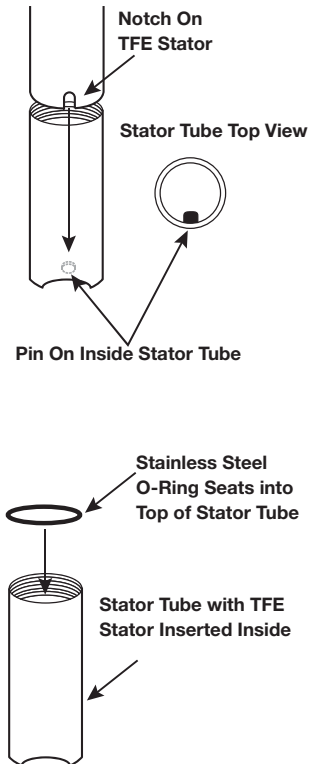

**Note:** Slide the TFE stator into the stator tube. Make sure the pin on the stator tube lines up with the notch on the TFE stator insert.

**Industrial Pump Models: SP-700SR & SP-700DD**

**SP-700SR & SP-700DD Spare Parts Lists**

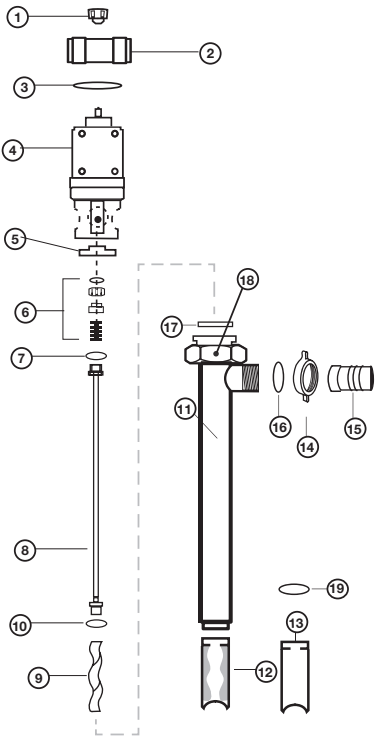

Figure 11 – SP-700SR

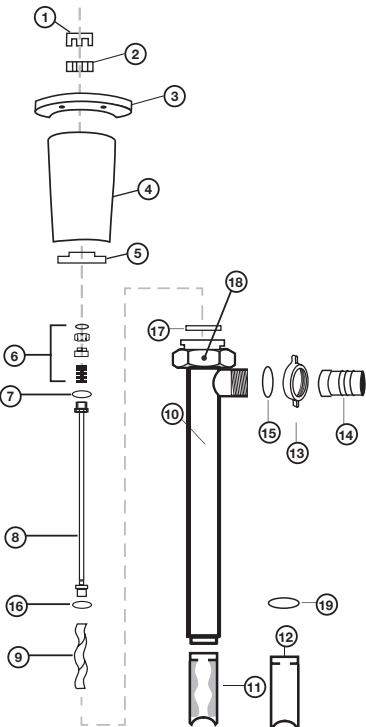

Figure 12 – SP-700DD

**SP-700SR** See Figure 11

Ref #	Description	P/N for SP-700SR
1	Pump Coupling	1004
2	Connection Nut, SS316	8842
3	Snap Ring, SS316	8208
4	Gear Reduction Unit, SS316	779
5	Mechanical Seal Bushing, SS316	702
6	Mechanical Seal, SIC	703
7	Gasket, PTFE	735
8	Drive Shaft, SS316	
	SP-751-27, SP-752-27, SP-1851-27	704
	SP-1851-39	705
	SP-751-39, SP-752-39, SP-1851-47	706
	SP-751-47, SP-752-47	707
9	Rotor, SS316	
	Size 751	708
	Size 752	709
	Size 1851	710
10	Gasket, PTFE	731
11	Outer Tube Assembly, SS316	
	SP-751-27, SP-752-27, SP-1851-27	770
	SP-1851-39	771
	SP-751-39, SP-752-39, SP-1851-47	772
	SP-751-47, SP-752-47	773
12	Stator	
	Buna* (SS316 Tube)	
	Size 751	816
	Size 752	817
	Size 1851	818
	PTFE (Stator Insert Only)	
	Size 751	822
	Size 752	823
	Size 1851	824
13	Stator Tube,** SS316	
	Size 751	874
	Size 752	875
	Size 1851	876
14	Wing Nut, SS316	727
15	Hose Barb, SS316	
	1.25" (32 mm)	728
	1.5" (38 mm)	729
16	O-Ring,	
	PTFE	730
	Buna	730B
17	Gasket,	
	Buna	737
	PTFE	738
18	Set Screw, SS316	757
19	Ring, SS316 (For Use with Teflon Stator Only)	0016

\*Includes Stator & Stator Tube. \*\* Does not include Stator..

**SP-700DD** See Figure 12

Ref #	Description	P/N for SP-700DD
1	Motor Coupling (Not Included with Pump Tube)	
	Models:	
	SP-502, SP-504, SP-508 & SP-A8FP	
	24mm	740
	Model: SP-A4FP	
	14mm	744
	Model: SP-A6FP	
	19mm	747
	Models:	
	SP-512, SP-514, SP-518, SP-522, SP-524, SP-528	
	28mm	746
2	Coupling Insert	745
3	Motor Mount Flange, Aluminum	
4	Bearing Housing Assembly, Aluminum	759
5	Mechanical Seal Bushing, SS316	702
6	Mechanical Seal, SIC	703
7	Gasket, PTFE	735
8	Drive Shaft, SS316	
	SP-751-27, SP-752-27, SP-1851-27	704
	SP-1851-39	705
	SP-751-39, SP-752-39, SP-1851-47	706
	SP-751-47, SP-752-47	707
9	Rotor, SS316	
	Size 751	708
	Size 752	709
	Size 1851	710
10	Outer Tube Assembly, SS316	
	SP-751-27, SP-752-27, SP-1851-27	770
	SP-1851-39	771
	SP-751-39, SP-752-39, SP-1851-47	772
	SP-751-47, SP-752-47	773
11	Stator	
	Size 751	816
	Size 752	817
	Size 1851	818
	PTFE (Stator Insert Only)	
	Size 751	822
	Size 752	823
	Size 1851	824
12	Stator Tube,** SS316	
	Size 751	874
	Size 752	875
	Size 1851	876
13	Wing Nut, SS316	727
14	Hose Barb, SS316	
	1.25" (32 mm)	728
	1.50" (38 mm)	729
15	O-Ring,	
	PTFE	730
	Buna	730B
16	Gasket, PTFE	731
17	Gasket,	
	Buna	737
	PTFE	738
18	Set Screw, SS316	757
19	Ring, SS316 (For Use with Teflon Stator Only)	0016

## Industrial Pump Models: SP-700SR & SP-700DD

### Operation and Safety Guidelines

- Use only metallic pump tubes with explosion proof motors to transfer flammable or combustible liquids.
- Area for use must comply with NFPA 30 guidelines for safe storage and use of flammable and combustible liquids.
- All containers and other equipment must be metal and grounded.
- Follow NGPA 77 guidelines for control of static electricity.
- Avoid splashing. Splash filling can create static electricity and is extremely hazardous.
- Fluid velocity must be 3 feet/second (0.91 meters/second) maximum 7 GPM in 1" hose (26.5 LPM in 25 mm hose).

### Use Of Air Motors In Hazardous Atmospheres

#### SP-A4, SP-A6 & SP-A8 Series

At the present time, there are no known standards governing the operation of air motors in hazardous atmospheres. However, there are several points regarding the safety of air motors.

First of all, an air motor is not a source of electric sparks. However, it is possible that an article which is not part of the air motor (e.g., wrenches, hammers, etc.) could create a spark by sharply impacting a cast iron or

aluminum case or the steel shaft of the air motor. (Note that electric motor enclosures for both class I and II hazardous locations can be made of "...iron, steel, copper, bronze, or aluminum..." (UL 674, Electric Motors and Generators – Hazardous Locations, June 23, 1989; paragraph 4.2, page 6). Second, an air motor housing is not designed to contain an internal explosion as is an explosion-proof electric motor. The only possible internal source of ignition in an air motor is a contact between the station housing components and the rotating elements that might create a spark. The likelihood of this occurring is reduced by the fact that the contact must be made at precisely the same time as a flammable or explosive gas is introduced into the air motor in a sufficient quantity to achieve a flammable or explosive mixture while overcoming the positive pressure of the driving gas. In other words, although highly improbable, an internal explosion in an air motor is possible. Finally, an air motor is designed to be operated by compressed air, the expansion of which in normal operation creates a cooling effect. As a result, the temperature of the air motor will not exceed the height of the temperatures of the surrounding atmosphere or the air delivered to the inlet.

We do not guarantee the safety of every application, but to ensure the safe operation of an air motor in your application, always follow the product direction and consult with a qualified engineer. (Source: Gast Manufacturing, Air Motors Handbook, page 2) Note: This statement is only applicable in North America.

**⚠ WARNING** *When using an SP-A4, SP-A6 or SP-A8 Series motor, Standard Pump recommends the use of a Filter Lubricator Regulator (FLR) in order to ensure a moisture free supply of air to the motor.*

**⚠ WARNING** *SP-A4, SP-A6 or SP-A8 Series motors must be lubricated daily to ensure proper functionality*

### Grounding Procedures

**⚠ WARNING** *Transferring of flammables or use in hazardous duty. Bonding is an electrical connection between a primary metal vessel and a metal receiving vessel. See schematic.*

Grounding is an electrical connection between a metal vessel, pump, motor and a constant ground; i.e. a metal rod driven into the earth.

Bonding and grounding are required when pumping flammable materials or in hazardous duty environments. Failure to bond and ground properly can cause a discharge of static electricity resulting in fire, injury or death. Follow NFPA 77 and 30 procedures at all times. If in doubt, do not start pump! Be sure bonding and grounding wires are secure before starting operation. (Ground and bond wires must have less than one ohm resistance for safe usage. Check continuity before starting). Always check with a safety engineer when any question arises and periodically check safety procedures with a safety engineer.

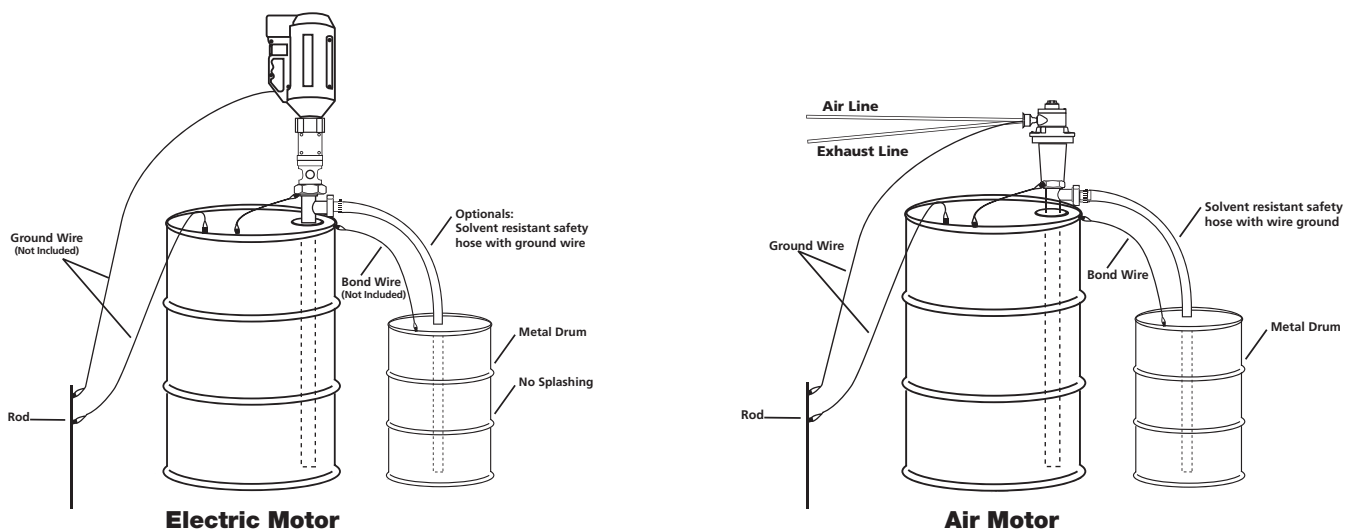

Figure 13 - Static Protection Kit

# North America Declaration of Conformity

We herewith declare that the construction type

Designation: **SP-280P**  
**SP-280P-V**  
**SP-ENC**  
**SP-ENC-V**

Machine type: Electric Motors for drum pumps

Item No: **SP-280P**  
**SP-280P-V**  
**SP-ENC**  
**SP-ENC-V**

In the form as delivered by us complies with following applicable regulations:

Conforms to UL STD 1004-1  
Certified to CSA STD C22.2 No. 100  
ETL Control number 5003012

RECOGNIZED  
COMPONENT



**Intertek**

Official responsible for documentation:

1 FEB 2016

Standard Pump, Inc.  
Duluth, GA USA

A handwritten signature in cursive script that reads 'Chris Murphy'.

**Christopher Murphy**  
Director of Operations



# EC Declaration of Conformity

We herewith declare that the construction type

Designation:	<b>SP-280P-2</b>	<b>SP-280P-2-NL</b>
	<b>SP-280P-2-V</b>	<b>SP-280P-2-V-NL</b>
	<b>SP-ENC-2</b>	<b>SP-ENC-2-NL</b>
	<b>SP-ENC-2-V</b>	<b>SP-ENC-2-V-NL</b>

Machine type: Electric Motors for drum pumps

Item No:	<b>SP-280P-2</b>	<b>SP-280P-2-NL</b>
	<b>SP-280P-2-V</b>	<b>SP-280P-2-V-NL</b>
	<b>SP-ENC-2</b>	<b>SP-ENC-2-NL</b>
	<b>SP-ENC-2-V</b>	<b>SP-ENC-2-V-NL</b>

In the form as delivered by us complies with following applicable regulations:

Machine Safety	2006/42/EC
Low Voltage Equipment	2006/95/EC
Electromagnetic Compatibility	2004/108/EC
RoHS Directive	2011/65/EU

Applied harmonized standards:

EN ISO 12100-1, -2	EN 60204-1
--------------------	------------

EC official responsible for documentation:

24 AUG 2015  
Date

Standard Pump, Inc.  
Duluth, GA USA

---

Christopher Murphy  
Director of Operations

# Warranty

---

## Three year limited warranty

Standard Pump, Inc. warrants, subject to the conditions below, through either Standard Pump, Inc., its subsidiaries, or its authorized distributors, to repair or replace free of charge, including labor, any part of this equipment which fails within **three years** of delivery of the product to the end user. Such failure must have occurred because of defect in material or workmanship and not as a result of operation of the equipment other than in accordance with the instructions given in this material. Specific exceptions include:

- Consumable items such as motor brushes, bearings, couplings and impellers. (Motor brushes typically have a life span of approximately 250 hours. This will vary with the manner in which the motor is used)

Conditions of exceptions include:

- Equipment must be returned by prepaid carriage to Standard Pump, Inc., its subsidiary or authorized distributor.
- All repairs, modifications must have been made by or with express written permission by Standard Pump, Inc., its subsidiary or authorized distributor.
- Equipment which have been abused, misused, or subject to malicious or accidental damage or electrical surge are excluded.

Warranties purporting to be on behalf of Standard Pump, Inc. made by any person, including representatives of Standard Pump, Inc, its subsidiaries, or its distributors, which do not fall within the terms of this warranty shall not be binding upon Standard Pump, Inc. unless expressly approved in writing by a Director or Manager of Standard Pump, Inc. Information for returning pumps Equipment which has been contaminated with, or exposed to, bodily fluids, toxic chemicals or any other substance hazardous to health must be decontaminated before it is returned to Standard Pump, Inc, or its distributor. A returned goods authorization number (RGA #) issued by Standard Pump, Inc., its subsidiary or authorized distributor, must be included with the returned equipment. The RGA # is required if the equipment has been used. If the equipment has been used, the fluids that have been in contact with the pump and the cleaning procedure must be specified along with a statement that the equipment has been decontaminated.

## STANDARD PUMP

1610 Satellite Blvd., Suite D. Duluth, Georgia 30097 USA  
TOLL FREE 1-866-558-8611 • Phone 770-307-1003 • Fax 770-307-1009  
e-mail: [info@standardpump.com](mailto:info@standardpump.com)  
[www.standardpump.com](http://www.standardpump.com)

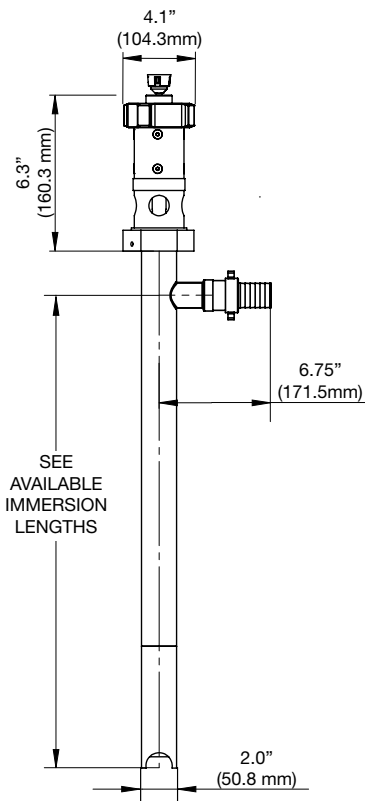

## Common Applications

- Polymers
- Oils & Greases
- Resins
- Paints
- Adhesives
- Varnishes

## Technical Specifications

<b>Pump Design:</b> .....	Progressive Cavity / Positive Displacement
<b>Discharge:</b> .....	1 1/2" Hose Barb
<b>Wetted Materials:</b> .....	SS316L, SiC/Viton & PTFE or Buna ( <i>varies by model</i> )
<b>Motor Drive Options:</b> .....	110V & 220V 1 Ph, 220V Explosion Proof
<b>Maximum Viscosity:</b> .....	<b>751 &amp; 752 Series :</b> 25,000 cps (mPas)*
.....	<b>1851 Series :</b> 10,000 cps (mPas)*
<b>Maximum Discharge Pressure:</b> .....	<b>751 &amp; 1851 Series :</b> 87 psi (6 bar)
.....	<b>752 Series :</b> 174 psi (12 bar)
<b>Maximum Flow Rate (based on water)</b> .....	<b>1851 Series :</b> 12 gpm (45,4 lpm)
.....	<b>751 &amp; 752 Series :</b> 7 gpm (26,5 lpm)
<b>Maximum Temperature:</b> .....	PTFE Stator : 300°F (149°C)
.....	Buna Stator : 185°F (85°C)
<b>Duty Cycle:</b> .....	Intermittent (30 min intervals)
<b>Available Immersion Lengths:</b> .....	27" (700 mm), 39" (1000 mm) & 47" (1200 mm)
<b>Maximum Particulate Size (Dia.):</b> .....	1/4" (6,35 mm)
<b>Surface Finish:</b> .....	32 Ra

**Warning:** When pumping flammable or combustible liquids, pump tube must be used in conjunction with an explosion proof or air motor.  
**\*Note:** Consult factory regarding products that are sticky in nature as the maximum rated viscosity of this pump may be lower for these types of products.

## Performance Curves

### 751 Series Pumps

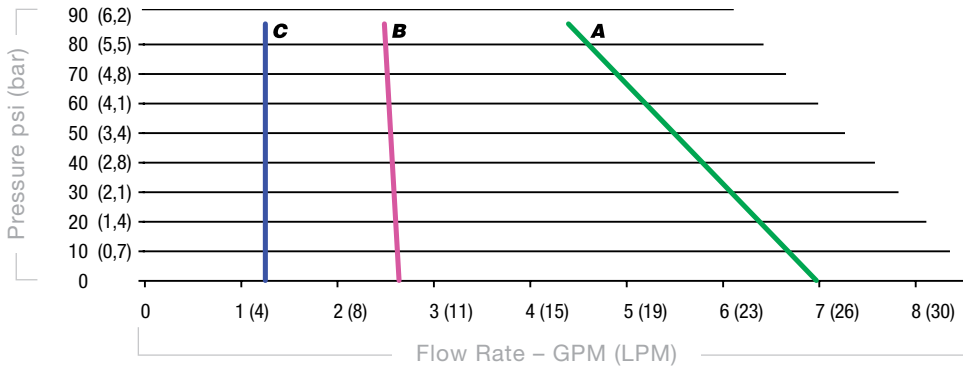

Viscosity cps (mPas)	Electric Motor
A 1	SP-ENC Series, SP-400 Series
B 10,000	SP-ENC Series, SP-400 Series
C 25,000	SP-ENC Series, SP-400 Series

### 752 Series Pumps

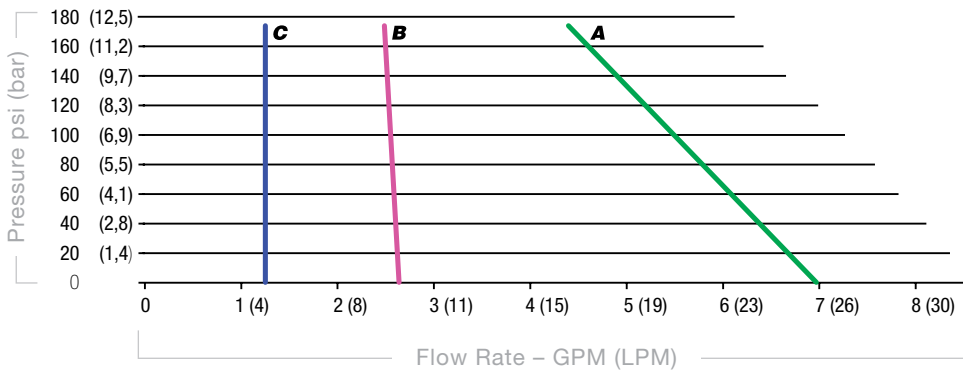

Viscosity cps (mPas)	Electric Motor
A 1	SP-ENC Series, SP-400 Series
B 10,000	SP-ENC Series, SP-400 Series
C 25,000	SP-ENC Series, SP-400 Series

### 1851 Series Pumps

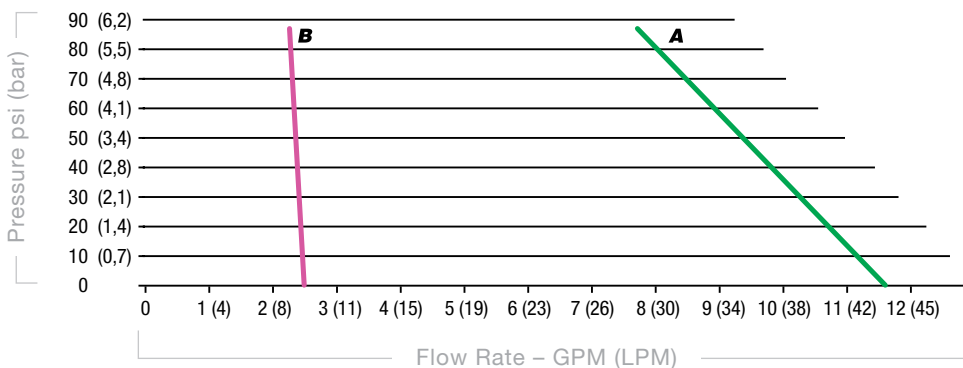

Viscosity cps (mPas)	Electric Motor
A 1	SP-ENC Series, SP-400 Series
B 10,000	SP-ENC Series, SP-400 Series